

There are over 1000 different variations in total. To make it as easy as possible for you, we take care of the complete configuration of the handling device.

We will be happy to provide you with individual advice.



**Further information / details
can be found here:**



Mechanical engineering
Digital manufacturing
Automation
Metrology
Contract manufacturing
Plastics technology

NMH GmbH

Am Flugplatz 2 | D - 88367 Hohentengen
Telephone +49 (7572) 7619-0
Fax +49 (7572) 7619-29
info@nmh.de | www.nmh.de



Modular Handling Device

We create complete solutions for measuring, testing and assembly systems, from planning and production to installation and implementation.

Convince yourself of NMH -
Innovation is our world.



Below you can see the configuration options for our "modular handling device". In the first step, we select the basic version.

Ceiling guided:

Ceiling trolley

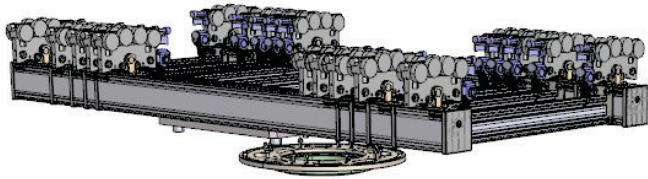

Rotary unit

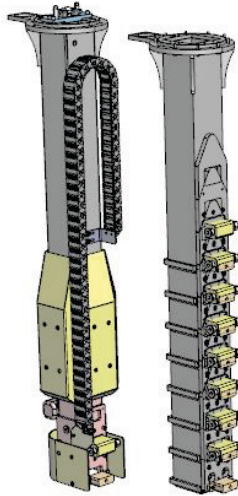

Outrigger:

In the second main step of the configuration, we select the length of the boom, depending on the desired radius of action.

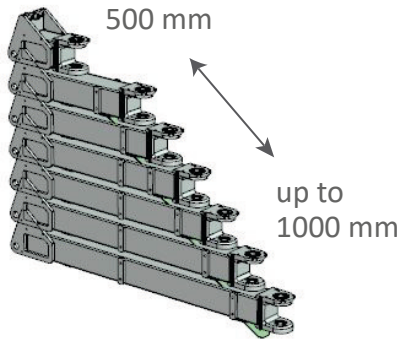

Parallelogram:

In the third main step of the configuration, we select the length of the parallelogram, depending on the desired stroke.

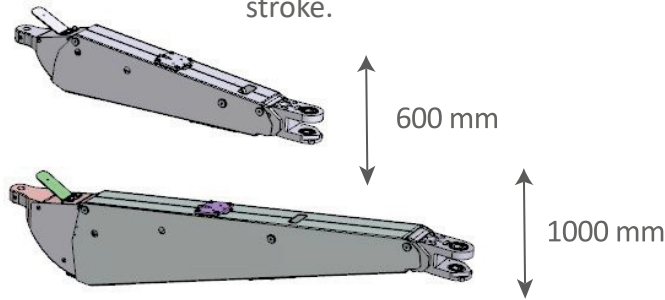

Floor guided:

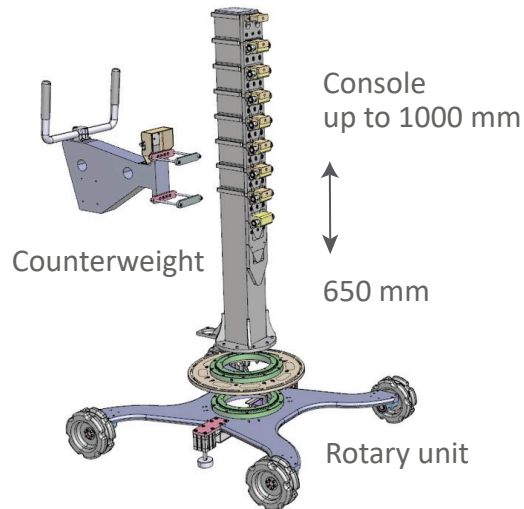

Possible fields of application:

- Lifting loads in general
- Overhead work
- Static holding during assembly
- Order picking
- Packing
- Filling
- Assembly assistant
- and many other possibilities

Your benefit:

- Increased quality through improved handling
 - Avoidance of worker overload
- Wide range of applications for employees
 - Reduced manufacturing costs through optimized processes
 - Resource-optimized processes
 - Reduce spinal problems
 - Streamlining of processes

Gripper:

The fourth main step in the configuration is the individual gripping device. This is developed and manufactured precisely to your individual requirements.

