

# CLAMPING TECHNOLOGY

We develop complete solutions for measuring, testing and assembly systems from the design to the final production, assembly and commissioning.

**See the difference for yourself. NMH –  
Innovation is our world**

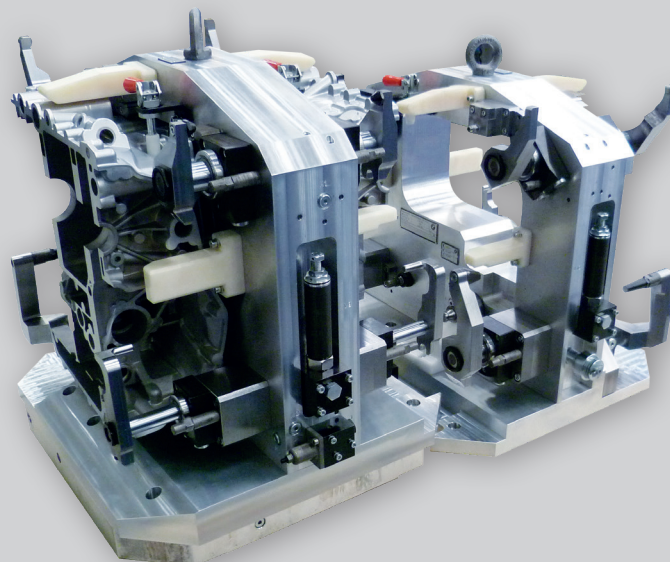

NMH

# CLAMPING FIXTURES AND FIX TURE CONSTRUCTION

- >> Consultation
- >> Design
- >> Production
- >> Service
- >> Decades of experience
- >> Worldwide references
- >> Everything from a single source

For decades, NMH has been planning, designing and producing everything from simple hand clamping fixtures to highly complex mechanical, pneumatic and / or hydraulic multi-way clamping fixtures, including hydraulic control units for low-pressure clamping or high-pressure clamping. Contact our experts.

## Company film

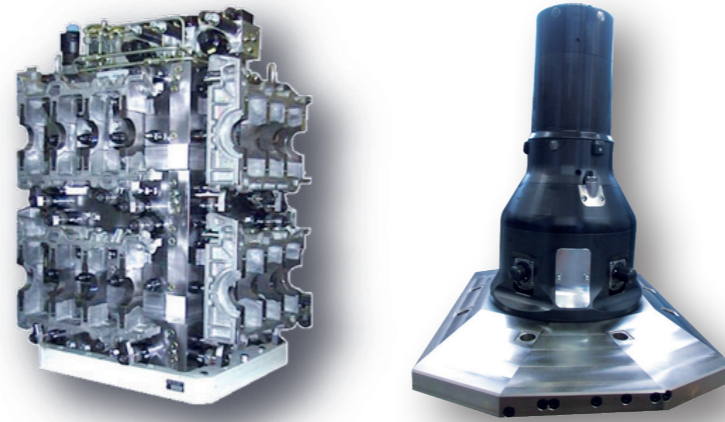

>> Dual-angle clamping fixture: Gearbox housing for commercial vehicle manufacturer

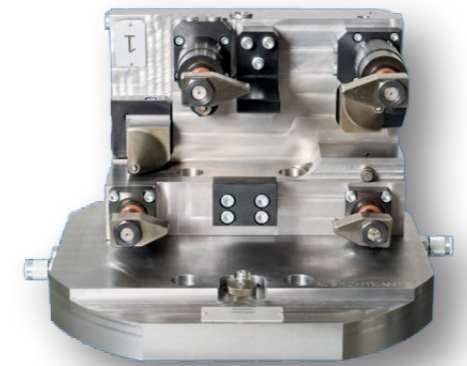
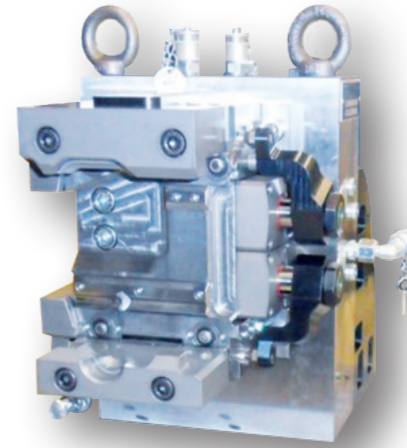

>> ABS housing clamping fixture

>> Mechanical steering column jacket clamping fixture

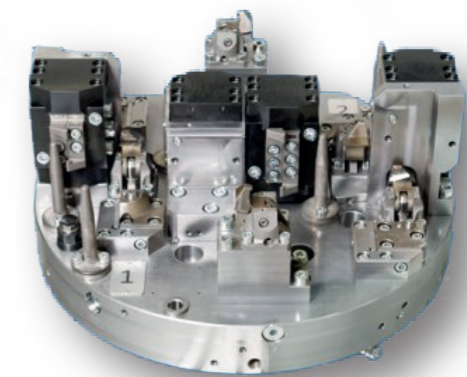
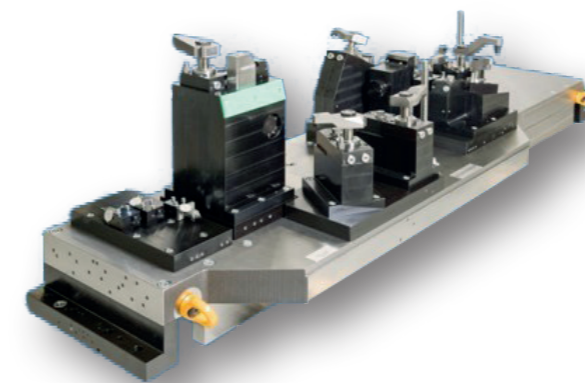
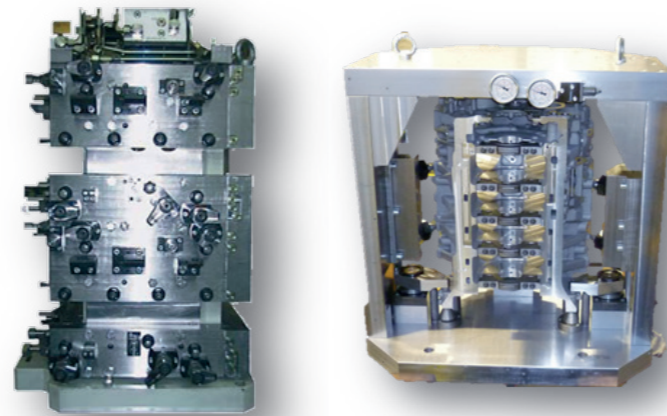

>> Longitudinal beam clamping fixture

>> Electrical steering column jacket clamping fixture

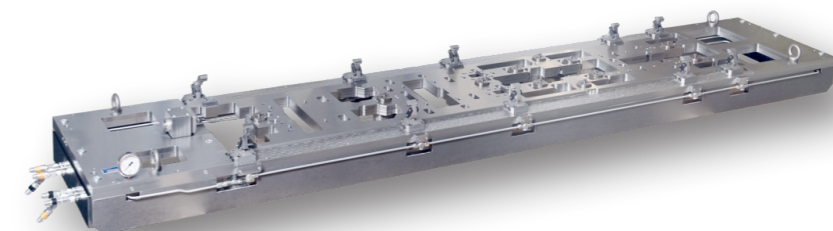
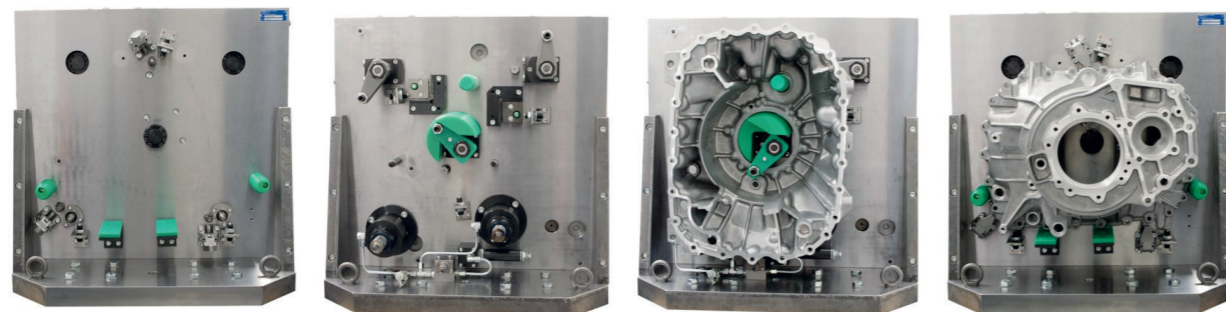

>> Antenna clamping fixture

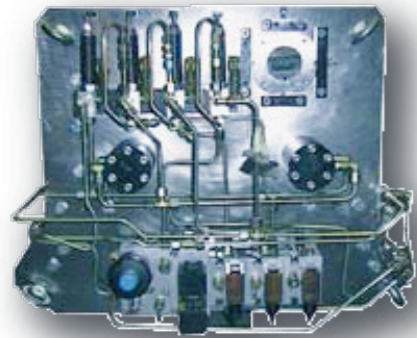

>> Clamping fixture: lorry crankcase with hydraulic control

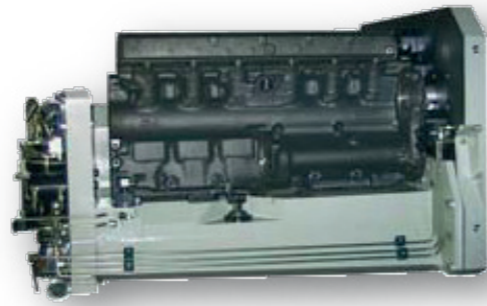

>> Clamping fixture: camshaft with hydraulic control for automotive manufacturer. Camshaft alignment by means of tooting on the shaft

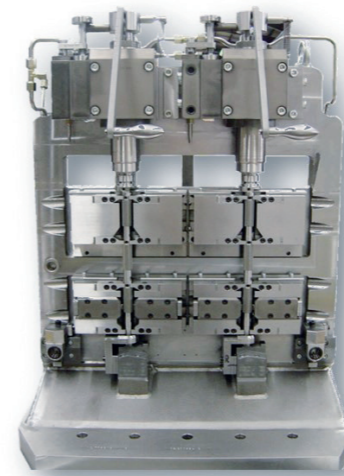

>> Lorry crankcase with hydraulic control clamping fixture

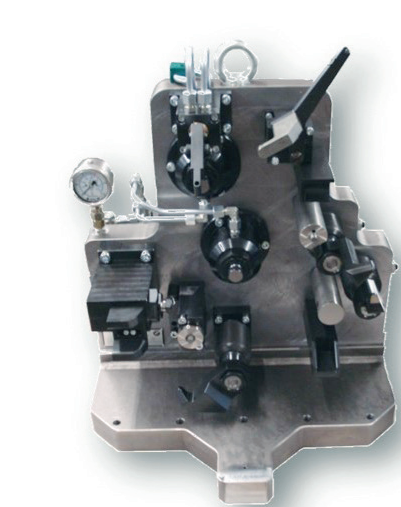
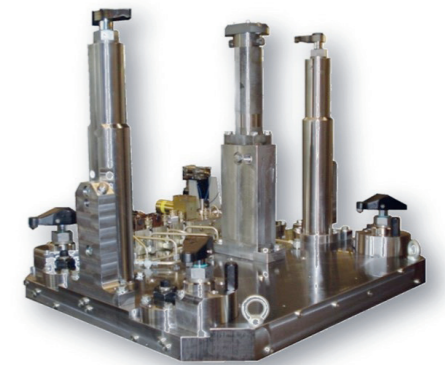

>> Lorry crankcase with hydraulic NMH control block clamping fixture

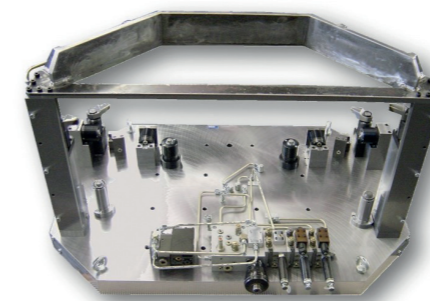

>> Pressure die casting clamping fixture

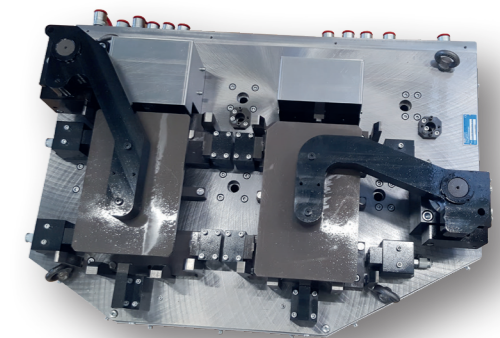

>> Clamping fixture: cylinder block with hydraulic control for motorcycle manufacturer

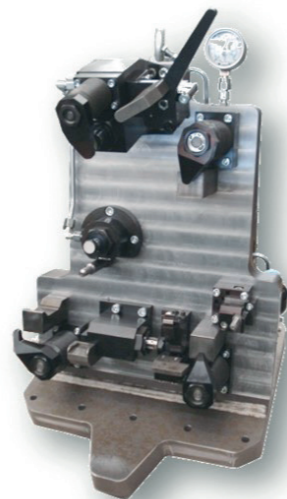

>> Clamping fixture: pressure die casting

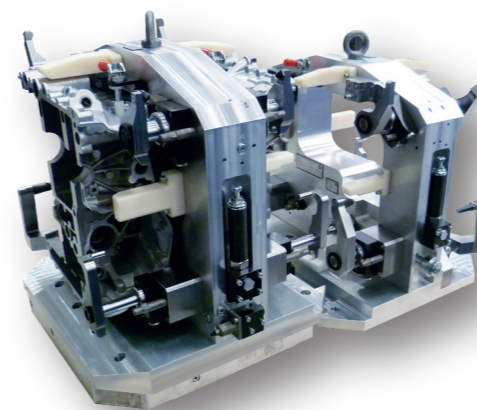

>> Clamping fixture: pressure die casting

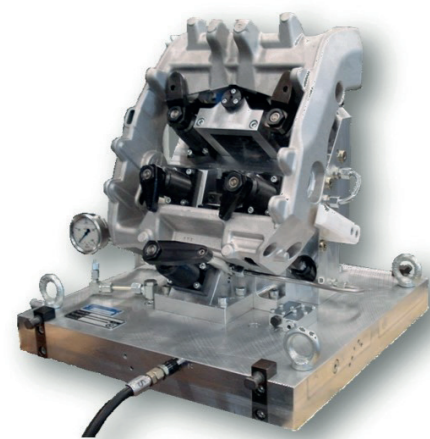

>> Clamping fixture: frame rear section with internal hydraulic control for motorcycle manufacturer

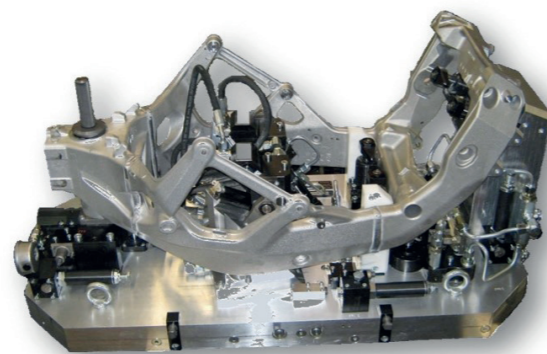

>> Clamping fixture: motorcycle frame with hydraulic control for motorcycle manufacturers



>> Four-way clamping fixture: compensating lug with hydraulic control

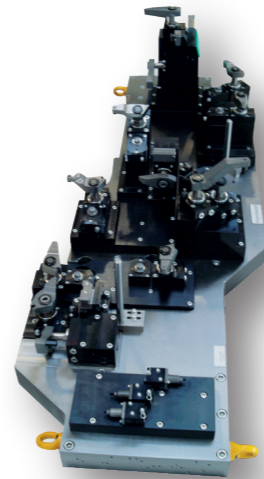

>> Crash profile clamping fixture

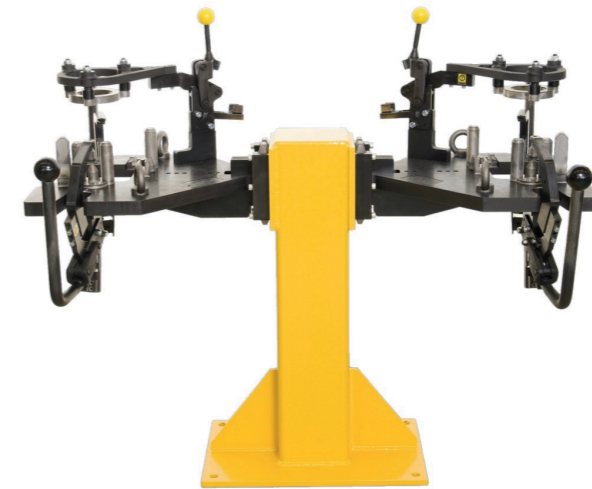

>> Manual double clamping fixture: corner module (wheel carrier) for motor vehicle

- >> Double clamping fixture for engine manufacturer in USA
  - > Valve plates are aligned and clamped hydraulically
  - > Machining takes place on 2 sides
  - > Base element and plate are deep-hole bored
  - > Loading with robots
  - > Max. clamping pressure 180 bar (pressure intensifier)

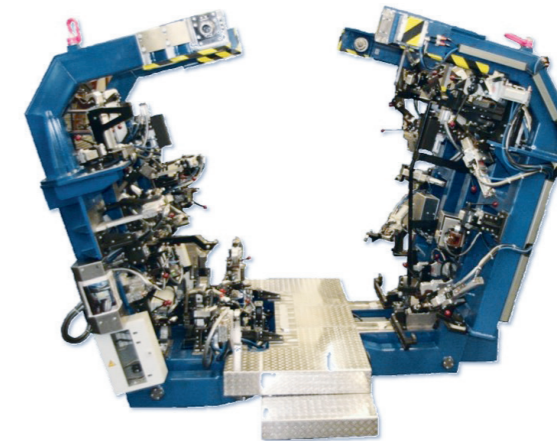
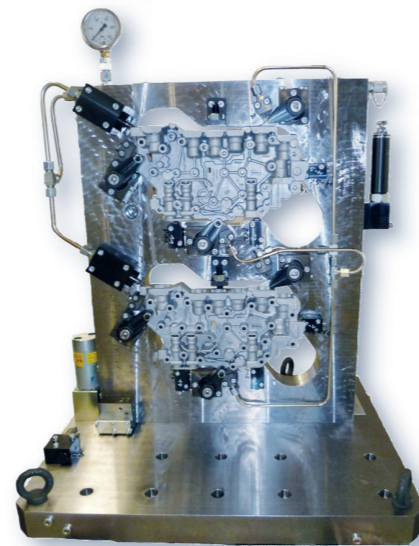

>> Robot welding fixture for agricultural tractor cab  
The prefabricated floor, roof and side elements are positioned securely for the process, then clamped and welded together in the automatically pivoting final welding fixture for cabs.

- >> Clamping fixture: V8-crankshaft with hydraulic control
  - > Crankshaft is clamped hydraulically between tips
  - > Carriage position is scanned by 2 limit switches
  - > Wireless signal transmission to the evaluation unit
  - > Crankshaft can be turned during machining

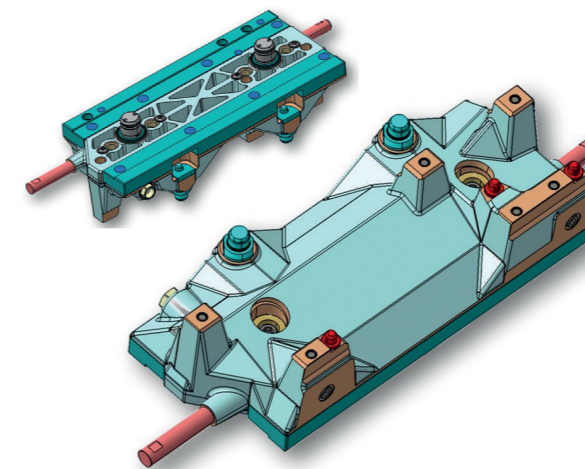
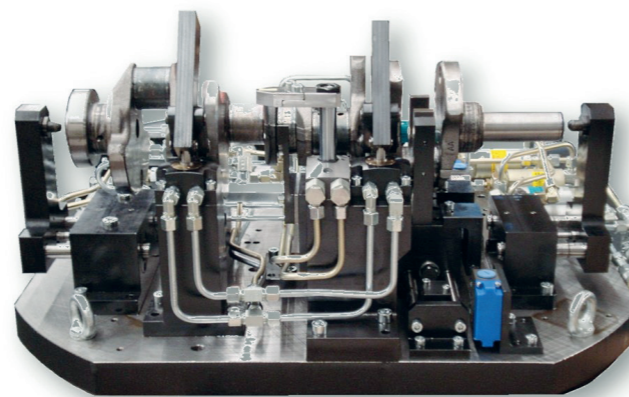

>> Adapter plate: for petrol / diesel cylinder head for motor vehicle manufacturer

**MORE THAN 3,400 CUSTOMERS  
WORLDWIDE – INNOVATION IS  
OUR WORLD**



**About NMH**

NMH is one of the “hidden champions” for complex measuring, testing and assembly systems. The company employs around 100 employees at the Hohentengen location. NMH offers complete solutions – from the design to the final production, assembly and commissioning. Nearly all German premium automotive manufacturers and their suppliers are NMH customers.

**Excerpt of  
references**



**Company film**



**NMH GmbH**  
Am Flugplatz 2 | D-88367 Hohentengen  
Telephone +49 (7572) 7619-0  
Fax +49 (7572) 7619-29  
info@nmh.de | www.nmh.de

